

Download manual

For detailed information on installation and commissioning, full version of the M100 manual can be downloaded at www.lselectric.co.kr

Verify & Identify the delivery

- Inspect the drive for damage. If the drive appears damaged upon receipt, contact your supplier.
- Verify receipt of the correct model by checking the information on the nameplate as shown below. If you have received the wrong model, contact your supplier.



LSLV0022M100-1EOFNS

INPUT 200-240V 1Phase 50/60Hz
10.0A

OUTPUT 0-Input V 3Phase 0.01-400Hz
3.8kVA

Ser. No 55025310146
Inspected by D. K. YU
KCC-REM-LSR-XXXXXX

LSLV 0022 M100 - 1 EOFNS

Motor capacity
0001 - 0.1kW 0008 - 0.75kW
0002 - 0.2kW 0015 - 1.5kW
0004 - 0.4kW 0022 - 2.2kW

Series name

Input voltage
1 - Single phase 200V - 240V

Keypad
E - LED keypad

UL type
0 - UL open type

EMC filter
F - Built-in EMC filter[C2]

DC Reactor
N - No built-in DC reactor

I/O
S - Standard type A - Advanced type

Mount the drive

- Ensure that there is sufficient space to meet the clearance specifications, and that there are no obstacles impeding the cooling fan's air flow as shown below.
- When installing multiple drives into the same enclosure panel (Side-by-side installation), mount the drives with the minimum clearance of 2 mm while removing optional top covers.

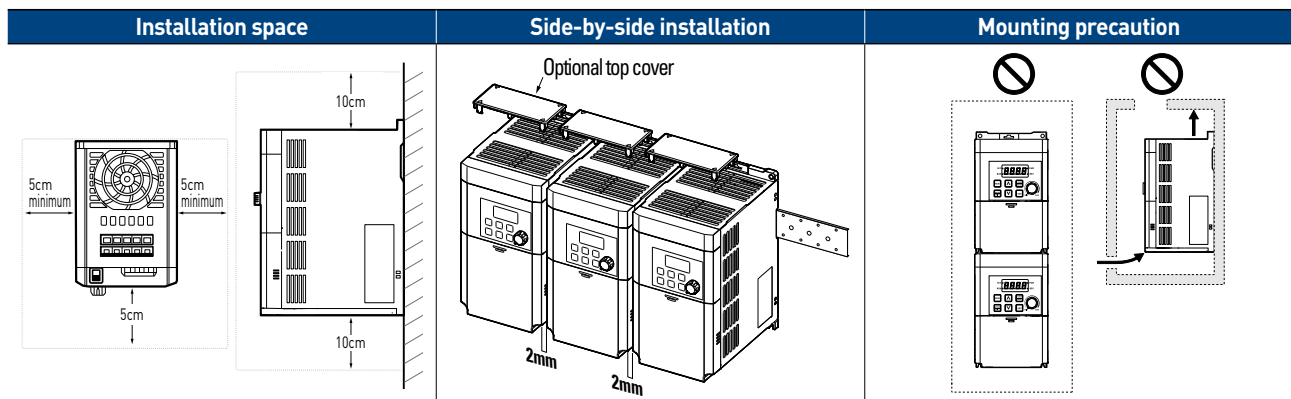

- Install the drive in an environment that meet the conditions such as ambient temperature (-10°C to 50°C), Humidity (95% relative humidity or free of condensation), altitude (below 1,000m) and vibration (below 1G [9.8 m/sec²])
- DIN rail mounting is available.

Connect drive: power

- The following figures show main circuit terminal arrangement on the drive.
- **WARNING!** B1, B2 terminals are for the brake resistor. Do not connect B1, B2 terminals to earth ground.
- **WARNING!** Power supply cables must be connected to R and T terminals.
Connecting power cables to the U, V, and W terminals will cause internal damage to the drive.

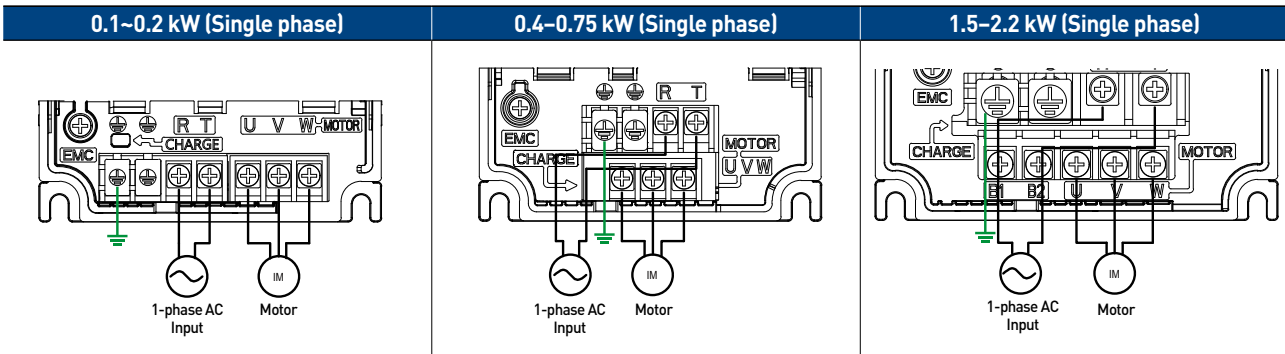

Connect drive: control

- The figures below show the control circuit terminal arrangement on the drive.
- Refer to the list of factory default value as below.

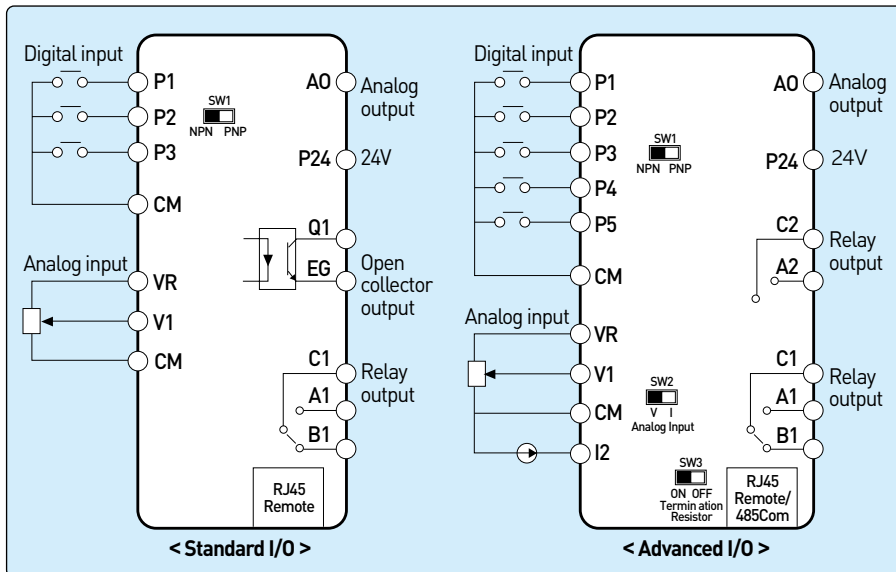

SW1	Sink/Source selection
SW2*	Voltage/Current selection for terminal I2
SW3*	RS485 termination resistor

Terminal	Parameter Code	Factory Default
P1	In-65	Fx
P2	In-66	Rx
P3	In-67	Emergency stop
P4*	In-68	RESET
P5*	In-69	JOG
V1	-	-
I2*	-	-

Terminal	Parameter Code	Factory Default
Q1/EQ**	OU-32	Fault
A1/B1/C1	OU-31	Fault
A2/C2*	OU-32	Fault
A0	OU-01	Output frequency

* This is available only on Advanced I/O

** This is available only on Standard I/O.

Keypad: description

No.	Name	Description
①	7-Segment Display	Displays current operational status and parameter information.
②	SET Indicator	LED flashes in parameter setting mode.
③	RUN Indicator	LED is lit during operation while flashing during acceleration or deceleration.
④	FWD Indicator	LED is lit during forward operation.
⑤	REV Indicator	LED is lit during reverse operation.

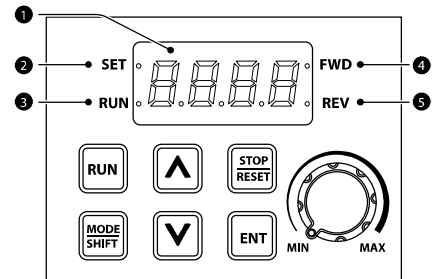

Key	Name	Description
	[RUN] key	Starts the drive. (Activates RUN command.)
	[STOP/RESET] key	STOP: Stops the drive. RESET: Resets the drive to clear fault situation.
	[▲] key, [▼] key	Scrolls up and down to select parameter codes, setting values, etc.
	[MODE/SHIFT] key	Moves the parameter groups or moves the cursor in parameter setting mode.
	[ENTER] key	Moves the value setting mode from the parameter selection mode. Saves the set values after adjusting the parameter values. Moves the drive status screen from the fault screen when a fault occurs.
	[Volume] key	Sets the output frequency.

Set parameters and monitor the operation

Set Parameters

※ Basic Parameters in Operation Group

- Only 18 parameters are shown in the first group to run the drive basically.
- The other groups are shown when "1" is set in the parameter OGr.
- Group Selection
 - The key allows to move from one group to the next in one direction only.
- Code Selection
 - The keys allow to select the parameter code.
- Parameters value setting
 - The keys allow to adjust parameter values.
 - The set value is saved by pressing the key twice.

Monitor The Operating Status

• Output Current Monitoring

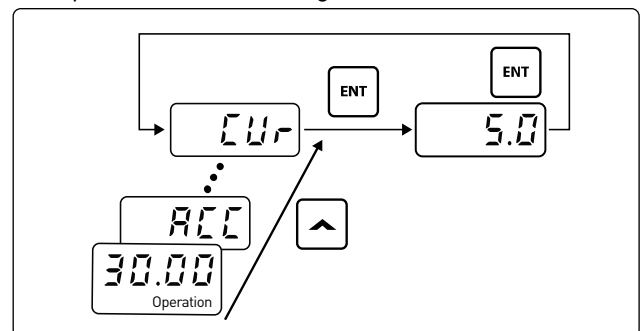

• Fault Trip Monitoring

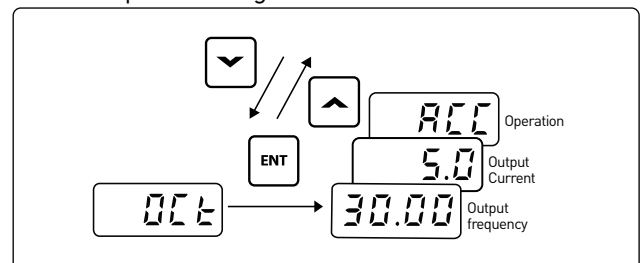

Basic set-up procedure

Motor direction inspection

- In this step the motor is checked for proper direction and operation. This test is to be performed solely from the Keypad. Apply power to the drive after all the electrical connections have been made and protective covers have been reattached.

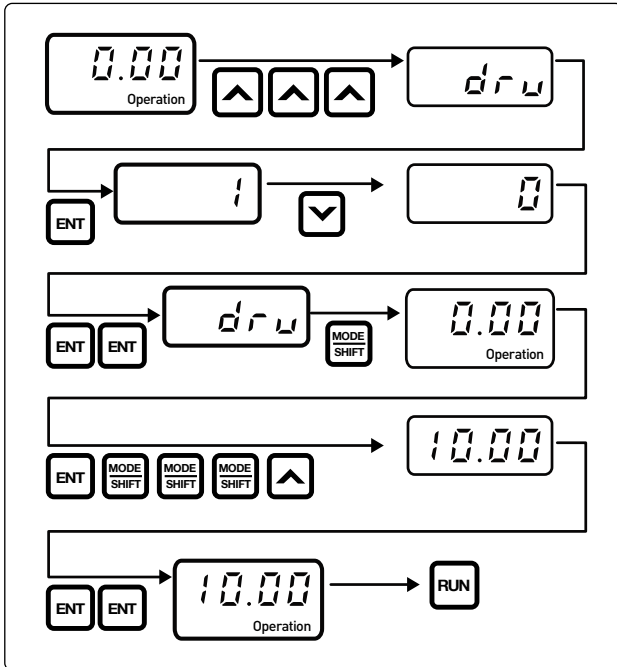

- Observe the motor's rotation from the load side and ensure that the motor rotates counterclockwise (forward).
- If the motor rotation is not correct, change the wiring of the motor. (ex. U-V-W → V-U-W)

Start/Stop and speed source settings

- This step shows how to setup the sequence and reference method of the drive. The sequence method determines how the drive receives its start and stop command and the reference method determines how the speed of the motor is controlled. Make sure all protective covers have been reattached and power is turned on.

- Select start / Stop method

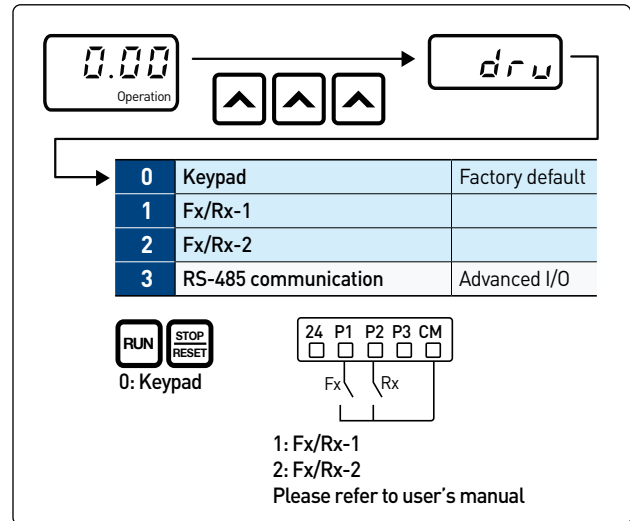

- Select frequency method

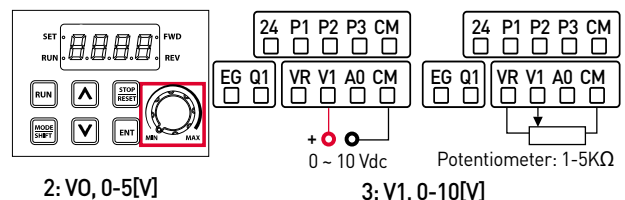
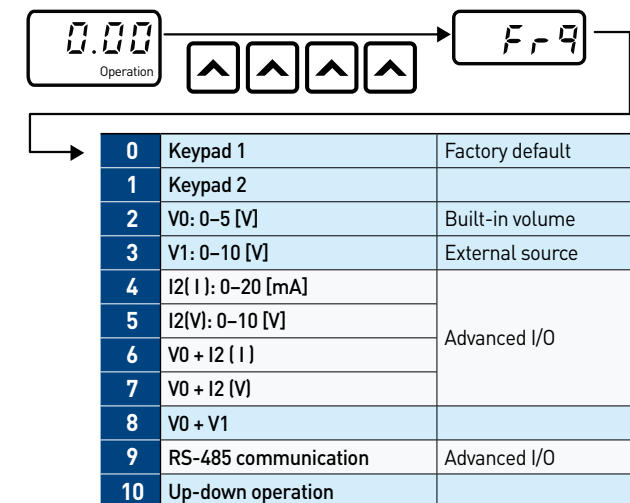

Multi-Step frequency

- This step shows how to set up and use the multi-step frequency of the drive.

Group	Code	Name	Parameter Setting
In	65	P1 function setting	5: Multi-step speed-low 6: Multi-step speed-middle 7: Multi-step speed-high
	66	P2 function setting	
	67	P3 function setting	
	68*	P4 function setting	
	69*	P5 function setting	

* This is available only on Advanced I/O

- Example)

* Command source: Terminal

* I/O Type: Advanced I/O

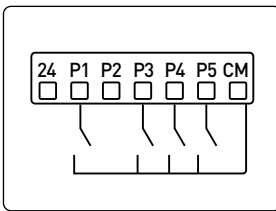

Group	Code	Setting Value
Op	drv	1 (default: value)
In	65(P1)	0 (default: value)
	67(P3)	5
	68(P4)	6
	69(P5)	7

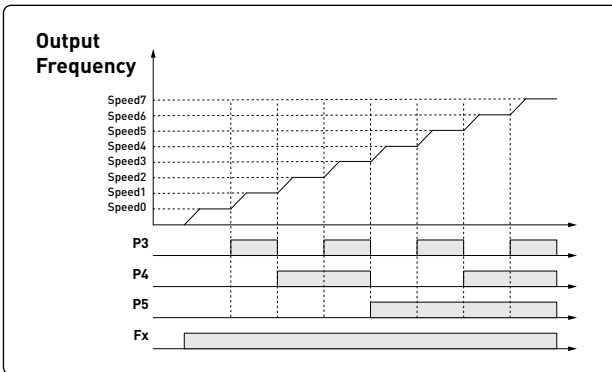

Speed	P5	P4	P3	Description
0	-	-	-	Reference source set with the Frq in the operation group
1	-	-	✓	bA51_Multi-step frequency 1
2	-	✓	-	bA52_Multi-step frequency 2
3	-	✓	✓	bA53_Multi-step frequency 3
4	✓	-	-	bA54_Multi-step frequency 4
5	✓	-	✓	bA55_Multi-step frequency 5
6	✓	✓	-	bA56_Multi-step frequency 6
7	✓	✓	✓	bA57_Multi-step frequency 7

Auto restart

- This step shows how to set up and use an Auto Restart function of the drive.
- This feature is enabled only when a digital input terminal is configured as a command input device.

Group	Code	Name	Setting Range
Pr	09	Auto restart count	0~10
	10	Auto restart delay time after trip	0.0~60.0 sec

※ If the reset signal is given manually via terminal or keypad, the restart count initializes to the set no. in Pr-09_Auto restart count.

※ When fault doesn't occur for 30 seconds, the remaining restart count recovers 1 by 1.

※ The Auto Restart function will not be activated if the drive stops due to the following fault trips:
- Low voltage, Emergency stop (Bx), Inverter overheating, or hardware diagnosis

- Example)

* Pr09=3, Pr09=5.0sec

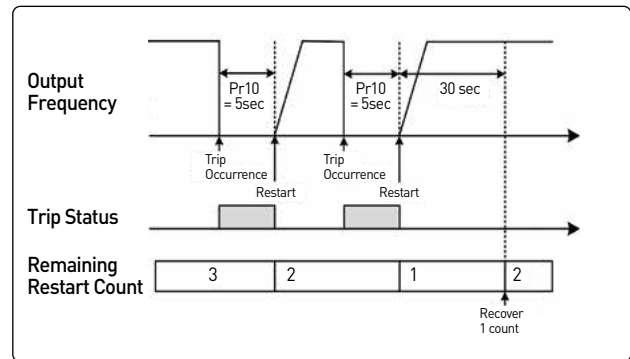

- Speed search - When a fault occurs, the motor is normally rotating at a free-run state. In order to operate the system without any additional fault due to rotating motor, speed search feature needs to be activated.

Group	Code	Name	BIT	Function
Cn	71	Speed search selection	--1- (0010)	Initialization after a fault trip

Basic parameter list

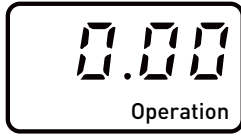

Operation	
0.00	Command frequency
ACC	Acceleration time
dEC	Deceleration time
drv	Command source
Frq	Frequency Setting method
MkW	Motor selection
MrC	Rated motor current
MbF	Base frequency
FrM	Maximum frequency
Iov	Output voltage setting
Ftb	Forward boost
Rtb	Reverse boost
Cur	Output current
rPM	Motor RPM
dCL	Inverter DC voltage
vOL, POr, tOr, v1M, I2M	User select signal
nOn	Currently out of order
OGr	Open hidden groups

※ Basic Parameters in Operation

- Only 18 parameters are shown in the first group to run the drive basically.
- The other groups are shown when "1" is set in the parameter OGr.



Drive
Basic
Advanced
Control
Input
Output
Communication
Application
Protection
2 nd Motor
Configuration

Drive	
09	Control mode
11	Jog frequency
15	Torque boost
19	Starting frequency
20	Select rotation direction
26	Automatic torque boost filter gain
27	Automatic torque boost motoring gain
28	Automatic torque boost regeneration gain
81	Select Monitor code
Basic	
04	Command source 2
05	Frequency source 2
07	V/F pattern
08	Unit of acc/dec time setting
09	Acc/dec frequency reference
11	Number of motor poles
12	Rated motor slip current
14	Motor no-load current
15	Motor efficiency
50 ~ 56	Multi-step frequency 1~ Multi-step frequency 7
Advanced	
01	Acceleration pattern
02	Deceleration pattern
03	S-curve start point gradient
04	S-curve end point gradient
08	Stop mode selection
09	Forward and reverse run prevention
10	Starting with power on selection
12	DC braking time at startup
13	DC braking rate at startup
14	Output blocking time before DC braking
15	DC braking time
16	DC braking rate
17	DC braking frequency
24	Frequency lower and upper limit
25	Frequency lower limit
26	Frequency upper limit
51	Energy saving operation
63	Motor RPM display gain
79	DB operation voltage
Control	
04	Carrier frequency settings
71	Speed search selection
Input	
08	V1 Minimum input voltage
09	Frequency corresponding to V1 minimum input voltage
10	V1 Maximum input voltage
11	Frequency corresponding to V1 maximum input voltage

65	Multi-function input terminal P1
66	Multi-function input terminal P2
67	Multi-function input terminal P3
68	Multi-function input terminal P4
69	Multi-function input terminal P5
70	PNP/NPN selection switch
90	Input terminal block status display
Output	
01	Analog output item setting
02	Analog output level adjustment
31	Multi-function relay setting
32	Multi-function output 2 feature selection
41	Output terminal block status display
Communication	
01	Inverter station ID
02	Communication protocol setting
03	Communication speed
04	Parity/stop bit setting
Application	
01	PID control setting
02	PID control unit selection
18	Amount of PID feedback
19	PID reference
20	PID reference setting
21	PID feedback setting
05	Output open-phase protection setting
08	Operation on reset after fault trip
09	Number of automatic restarts after fault trip
10	Automatic restart delay time after frult trip
18	Overload alarm level
19	Overload warning time
20	Overload warning selection
21	Overload fault level
22	Overload fault time
50	Stall prevention selection
79	Operation at fan fault
91 ~ 95	Fault history 1 ~ Fault history 5
2 nd Motor	
04	2nd motor acceleration time
05	2nd motor deceleration time
07	2nd motor base frequency
12	2nd motor rated current
Configuration	
01	Display after power on
02	I/O Type
79	Software version
93	Parameter initialization
94	Password registration
95	Parameter Lock

Frequently asked questions

Question: The motor does not rotate and the output current is too high at start.

- Cause: the load is too high. It can be solved by using manual/auto torque boost and changing some parameters.

1	Manual Torque Boost	Slightly increase the Forward or reverse boost in Ftb or rtb . If the torque boost level is too high, a trip may occurs such as IOL.
2	Auto Torque Boost(ATB)	Set dr15l to 1 to activate ATB. It is necessary to reduce manual boost values (ex. 0~2%) in Ftb or rtb , and then to adjust the values in dr26 , dr27 or dr28 .
3	Starting Frequency	Slightly increase the starting frequency in dr19 .(ex. 0.5 → 1.0 → 1.5 → 2.0Hz)
4	User V/F Pattern	When bA07 is set to 2 (User V/F), User V/F pattern can be set up according to the applications and motor characteristics.

Question: The motor makes humming sound or loud noises.

- Answer: Slightly increase or decrease the carrier frequency in **Cn04**.

Question: When the drive is running, the Earth-leakage circuit breaker(ELCB) is activated.

- Cause: The ELCB will disconnect the power if leakage current flows to grounding during drive operation.
- Answer1: Connect the drive to grounding terminal.
- Answer2: Check if the ground resistance is less than 100 Ω for 200V class.
- Answer3: Check the capacity of ELCB and connect it to the drive according to the rated current of the drive.
- Answer4: Reduce the carrier frequency in **Cn04**.
- Answer5: Attempt to keep the cable distance from the drive to motor short as possible.

Question: How do I reset the drive back to factory default settings?

- Answer: Set **CF93** to 1 (All groups) and press the [ENT] key. **CF93** is displayed again when the initialization has been completed.

Question: How do I adjust the time it takes the motor to speed up or slow down?

- Answer: Adjust the acceleration time in **ACC** and deceleration time in **dEC**.

Question: How do I prevent the drive from tripping on an OV fault (overvoltage) while the motor is ramping down?

- Answer 1: Increase deceleration time in **dEC**.
- Answer 2: Activate stall prevention in **Pr50**. To enable it during deceleration, set **Pr50** to “-1-” as Bit 2..

Question: How do I prevent the drive from tripping on an OLT(overload) while the motor is ramping up and down?

- Answer: Verify motor rated current in **MrC** and motor overload parameter settings such as **Pr20** (Overload trip selection), **Pr21** (Overload trip level) and **Pr22** (Overload trip time).

Question: How do I run the motor above the nominal motor speed?

- Answer: Increase Maximum Frequency in **FrM**.

Question: Does the drive create harmonics? If so, are they a problem?

- Answer: All standard drives create 5th and 7th harmonic frequencies. Occasionally, and this depends on the applications there may be issues and harmonics can cause problems such as transformer heating or interference with other communication devices installed near the drive. To reduce interference, the installation of noise filters or line filters may be required. Additionally it may be helpful to adjust the carrier frequency to the minimum value in **Cn04**.

Troubleshoot faults

Item	Type	Cause	Remedy
OLt (Over Load)	Latch	The load is greater than the motor's rated capacity.	Replace the drive and motor with larger models.
		The set value of Overload trip level in Pr21 is too low.	Increase the set value for of Overload trip level.
OcT (Over Current)	Latch	Acc/Dec times are too short compared to the load inertia (bA16).	Increase Acc/Dec times.
		The drive load is greater than the rated capacity.	Replace the drive with a larger model.
		The drive output is active while the motor is rotating.	Run the drive after the motor has stopped or Activate the speed search function (Cn71).
		The mechanical brake on the motor is activated too fast.	Check the mechanical brake.
Ovt (Over Voltage)	Latch	Deceleration time is too short compared to the load inertia in bA16.	Increase Deceleration time.
		A generative load occurs at the drive output.	Use a braking option.
		The input voltage is too high.	Check if the input voltage is above the specified value.
Lvt (Low Voltage)	Level	The input voltage is too low.	Check if the input voltage is below the specified value and adjust the drive input voltage value in bA19.
		The loads on the line power supply is greater than rated capacity such as welding machine, DOL motor, etc.	Increase the power capacity.
		The magnetic contactor on the line power supply line is defective.	Replace the magnetic contactor.
GfT (Ground Trip)	Latch	Ground fault has occurred in the out circuit.	Check the wiring in the drive.
		The motor insulation has been damaged.	Replace the motor.
EtH (E-Thermal)	Latch	The motor has overheated.	Decrease the load or reduce the motor operation.
		The drive load is greater than the rated capacity.	Replace the drive with a large model.
		The drive has been running at low speed for a long time.	Replace the motor that has a cooling fan sourced by independent power.
OPO (Out Phase Open)	Latch	The magnetic contactor in the output circuit is defective.	Check the magnetic contactor in the output circuit..
		The wiring to the output is defective.	Check the wiring to the output.
IOL (Inverter OLT)	Latch	The load is greater than the rated capacity of drive.	Replace the drive and motor with larger models.
		The torque boost level is too high.	Decrease the torque boost level.
Oht (Over Heat)	Latch	There is a problem with the cooling system.	Check if there is a foreign object in the air inlet, outlet, or vent.
		The cooling fan of the drive has been operated for a long time.	Replace the cooling fan.
		The ambient temperature is too high.	Keep the ambient temperature below 50°C.
ntC (NTC Open)	Latch	The ambient temperature is too low.	Keep the ambient temperature above -10°C.
		The internal temperature sensor has been damaged.	Contact your supplier or authorized service distributor of LS.
FAn (Fan Trip)	Latch	Foreign object is in the air vent of the drive.	Remove the foreign object from the air inlet or outlet.
		The lifespan of cooling fan is over.	Replace the cooling fan.
EtA, Etb (External Trip A,B)	Latch	When the multi-function input terminal is set to EtA or EtB, the terminal is assigned as the its signal.	Adjust the parameters related to External trip.
COM (Communication Trip)	Latch	It occurs when communication between the Main DSP and the IO CPU is disconnected for more than 500ms	-
nbr	Latch	It occurs when the output current of the drive is below the value set in Ad41 while OU31 or OU32 is set to 19 (Brake signal).	Adjust the parameters related to brake control.

*Level : automatically terminates when the failure is solved. This is not saved in the failure history.

*Latch : terminates when the reset signals are input after the failure is solved.